

TPOT* proposal for sPHENIX

A Micromegas detector to reconstruct space charge distortions in the SPHENIX TPC

Hugo Pereira Da Costa

CEA Saclay/LANL

on behalf of the sPHENIX TPOT team

NPP PAC meeting - June 22, 2021

(*) TPOT: TPc Outer Tracker

sPHENIX will take data for 3 years (2023-2025) and is committed to deliver its physics output well before EIC startup, before resources get redirected.

Requires robust, efficient and redundant calibration of the detectors

Especially true for the sPHENIX TPC

Main tracking device of sPHENIX, critical to sPHENIX HF and jet programs

The TPC is operated in continuous readout mode

No gating grid to stop the ions coming from the avalanche in the readout detectors

Sustains up to 50kHz Au-Au collision rate,
up to 3MHz pp collision rate

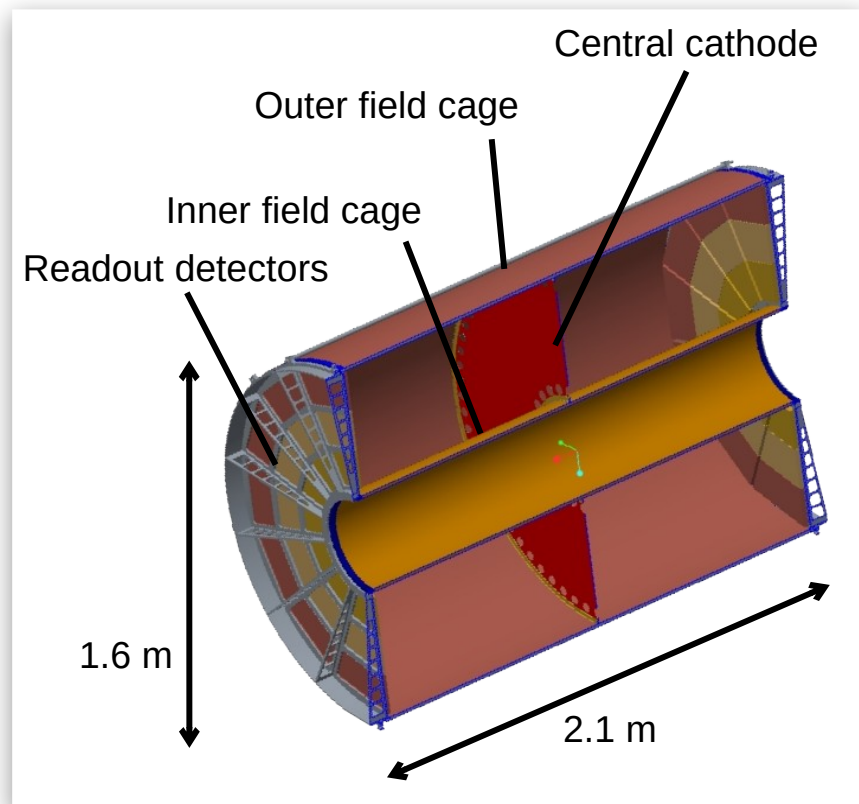

Distortions in the TPC

In an ideal TPC, primary electrons drift longitudinally at constant velocity v

Sources of distortions to the ideal case:

- **static distortions** due to E,B field inhomogeneities, alignment etc.
Length scale: O(1cm)
Measured during commissioning, without beam, once per year
- **beam-induced distortions** due to charges from primary ionization and IBF in drift volume, that create an additional position and time-dependent E field
Length scale: O(1mm)
Vary with luminosity and beam conditions, on time scale $\sim 1/2h$
- **event-by-event fluctuations** of the beam-induced distortions due to multiplicity/centrality fluctuations
Length scale: $< 100\mu m$
Time scale: O(10ms)

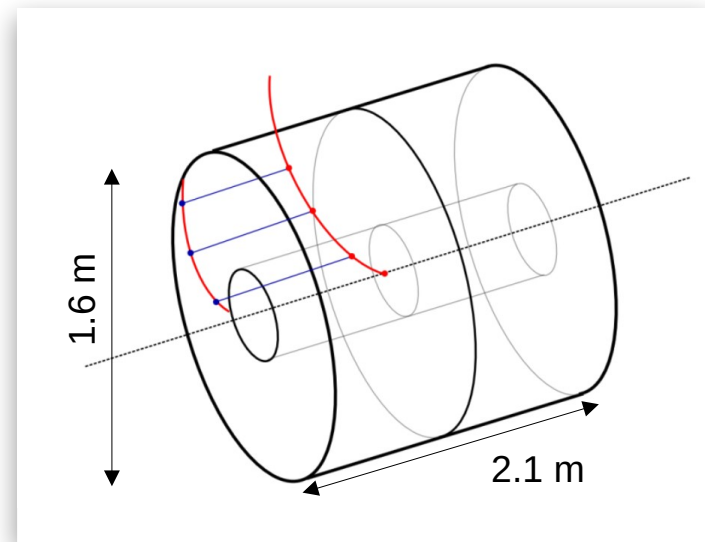

To meet its Ultimate Performance Parameters, sPHENIX must measure and correct these distortions to $< 100 \mu m$ accuracy

Means of reconstructing the distortions in the TPC

- 1) **directed lasers** to reconstruct static O(cm) distortions during commissioning
- 2) **tracks** to reconstruct beam-induced, O(mm) space-charge distortions
- 3) **diffuse laser (and digital currents)** to monitor event-by-event ($<100\mu\text{m}$) fluctuations

need all methods, cooperatively, to fully address distortions in the TPC to the required $100\mu\text{m}$ accuracy level

TPOT proposal relevant to using tracks for reconstructing beam-induced distortions

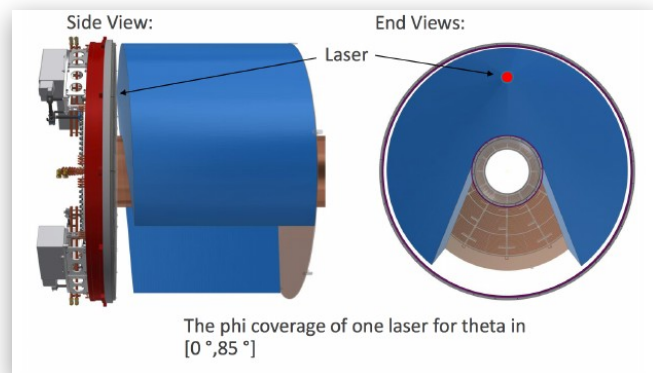

Direct laser trajectories

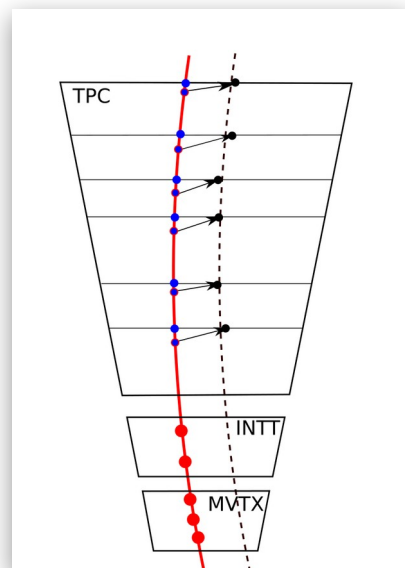

Track extrapolation to the TPC

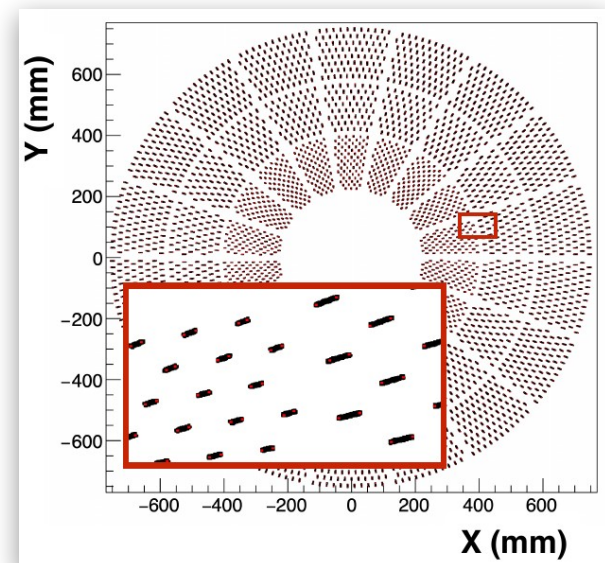

Central membrane metallic pads

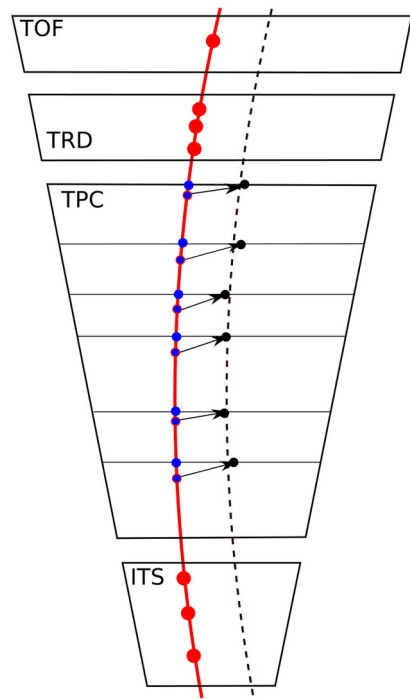

ALICE

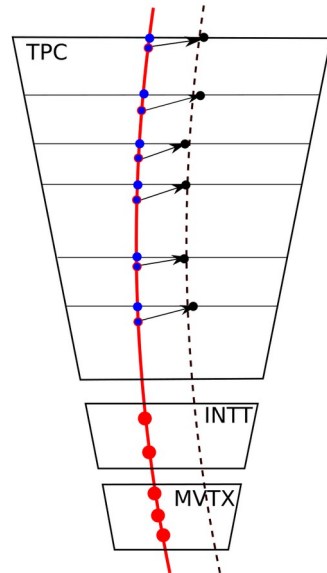

SPHENIX
baseline

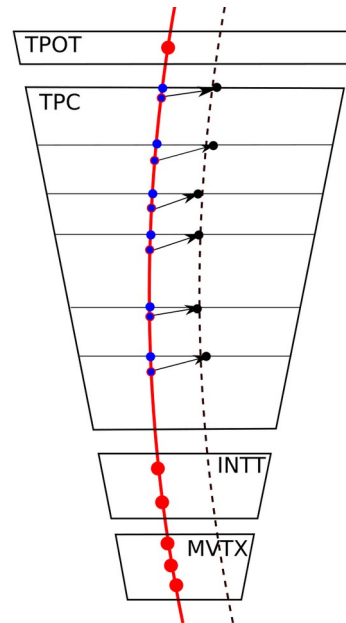

SPHENIX
+ TPOT

Principle

- Extrapolate tracks from detectors outside of the TPC
- Measure residuals between TPC clusters and tracks along $\Delta\Phi$ and ΔZ in small TPC volume elements
- Compute distortions along $\Delta\Phi$, Δz and Δr from measured residuals

Available detectors

ALICE: ITS, TRD and TOF

SPHENIX baseline: MVTX and INTT

TPOT is meant to provide an additional space point on the outside of the TPC, playing a similar role as TRD and TOF for ALICE

Adapted from EPJ. Web Conf. 245 (2020) 01003

Not to scale !

TPOT detector proposal

26 Micromegas modules, consisting of two detectors (z and ϕ layers) to provide one space point (2 x 1D measurements)

- detector technology: Bulk, resistive Micromegas built at CEA Saclay
- dimension: 50x25cm (active area)
- front-end: SAMPA (same as sPHENIX TPC, also used in ALICE)
- anticipated spatial resolutions: 200 μm (ϕ), 300 μm (z)

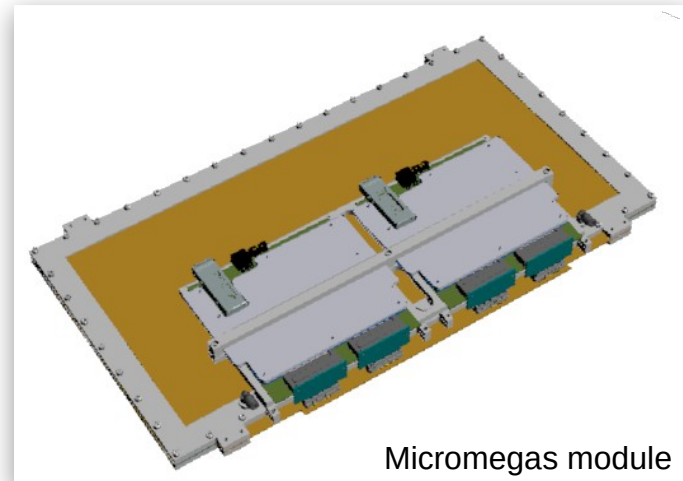

Covers key sections of the TPC acceptance:

- one module for each sector of the TPC on each side, due to sector-to-sector variations of IBF
- one sector of the TPC equipped with 4 modules to fully measure the z dependence of the distortions

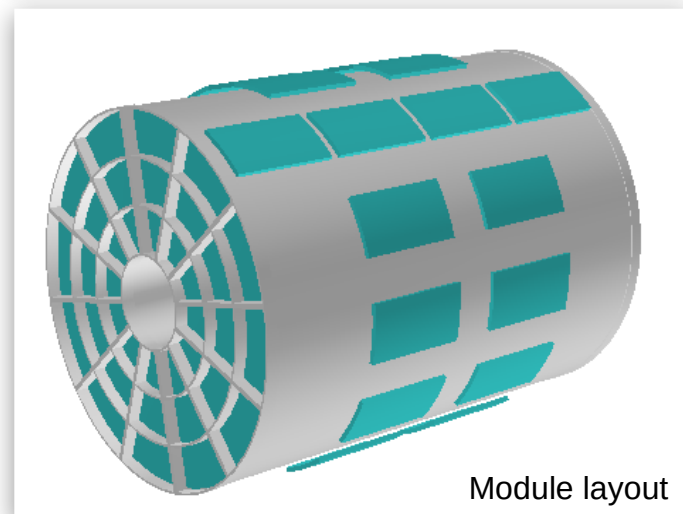

Remaining fraction of the acceptance covered by means of interpolation over short distances (see backups)

1) **TPOT allows to make the maximum use of tracks** to reconstruct space charge distortions, by improving track extrapolation accuracy in the TPC, thus reducing the weight on the other methods and enabling faster space charge reconstruction

2) **TPOT provides a direct measurement of full z dependence of the distortions**, in limited azimuth. This provides

- redundancy
- cross-check of other methods
- systematic uncertainties assessment

3) **TPOT ensures that sPHENIX will make the most out of collected data.** In particular it was verified that TPOT allows to calibrate the TPC even in the presence of distortions 2x larger than expectations

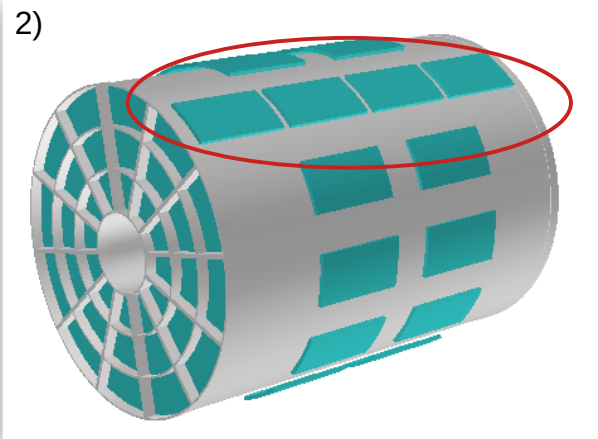
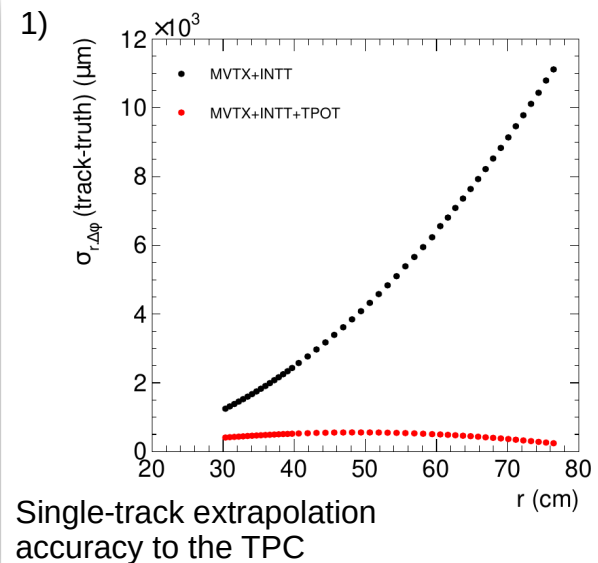

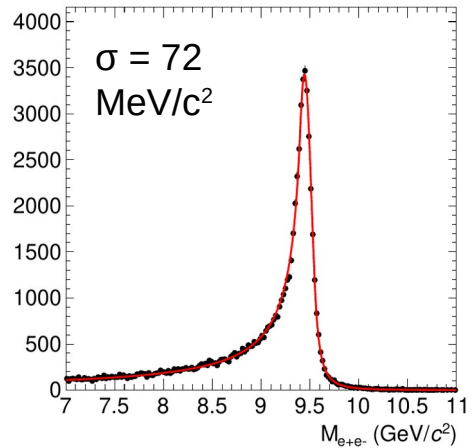

Nominal Upsilon invariant mass distribution in (ideal) simulations

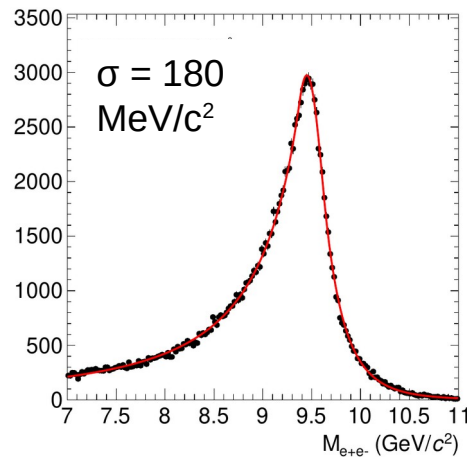

Upsilon invariant mass distribution, with time-averaged space charge distortions and track-based correction (INTT+MVTX)

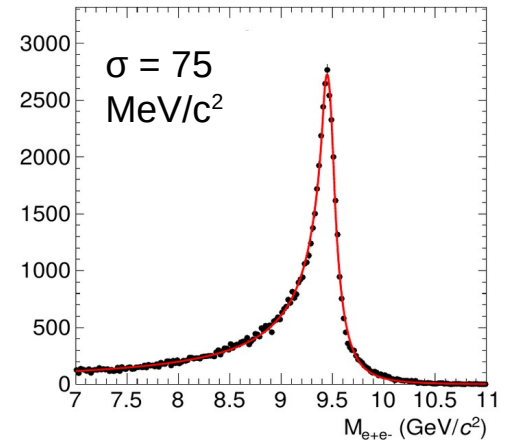

Upsilon invariant mass distribution, with time-averaged space charge distortions and track-based correction (INTT+MVTX+TPOT)

- Without TPOT, track-based corrections alone are not enough to recover the Upsilon inv. mass resolution
- With TPOT, one can recover the nominal inv. mass resolution, without relying on the other methods (lasers, digital currents)
- Same conclusion applies to charged particle momentum resolution, critical for sPHENIX HF and Jet program
- Shown performance are robust to distortions x2 larger than expected

Organizational chart (WIP) and participating institutions

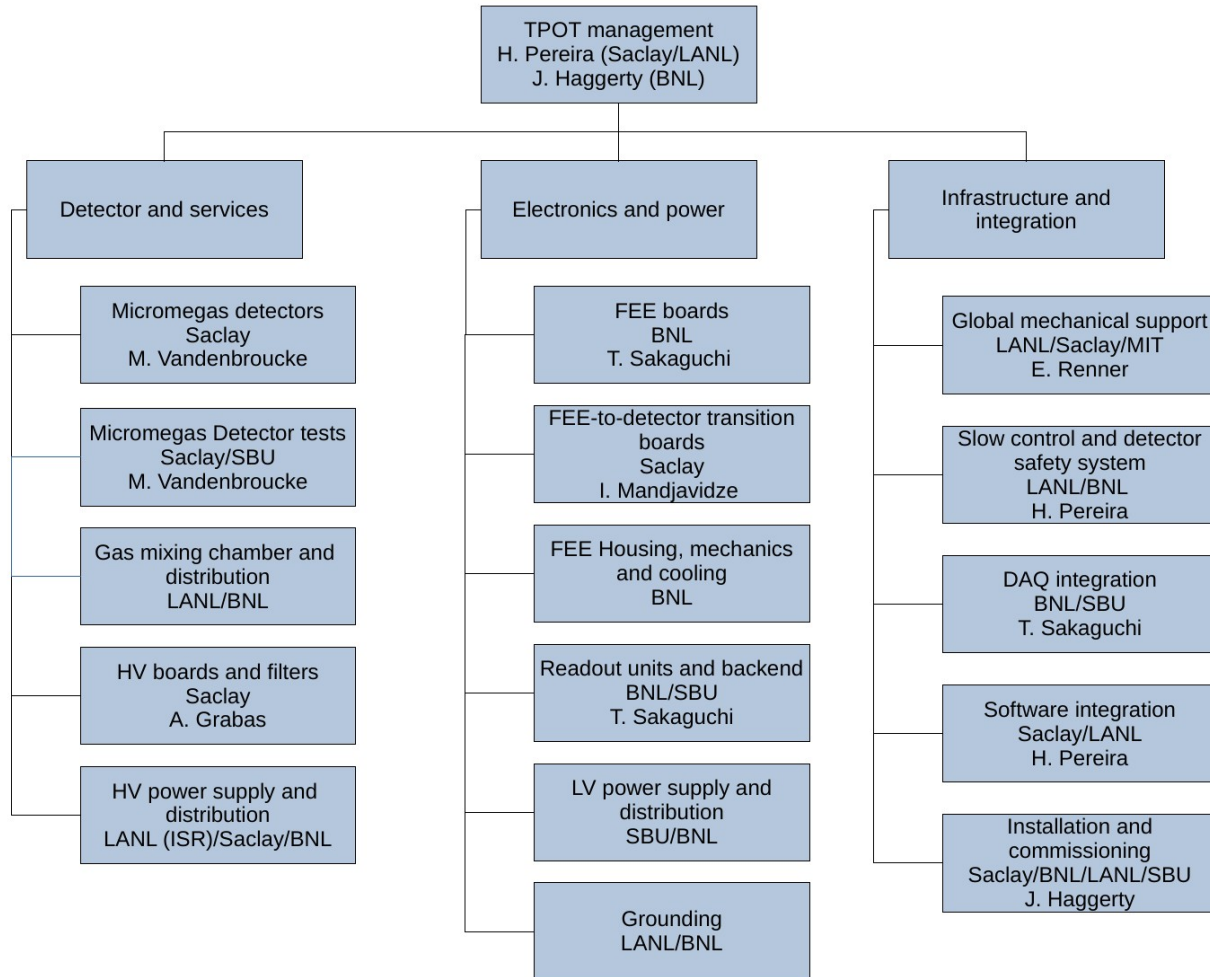

Institutions:

CEA: Micromegas detector, HV boards, FEE transition boards

LANL: mechanical integration, LV, HV, grounding, gas

MIT: mechanical support

SBU: FEE, DAQ integration

BNL: bit of everything but mostly consultative

More on TPOT pre-studies

Total cost estimated to \$2-\$2.5M (including burden and contingency)

Prototyping phase is ongoing, thanks to \$40k contract between BNL and CEA Saclay.

First prototypes available this summer

Detailed construction + installation schedule is WIP

To cope with very short deadline, staged installation is anticipated with

- 4 to 8 detectors (out of 26) installed for Run1 (2023) data taking
- remaining detectors installed for Run2 and Run3 (2024-2025)

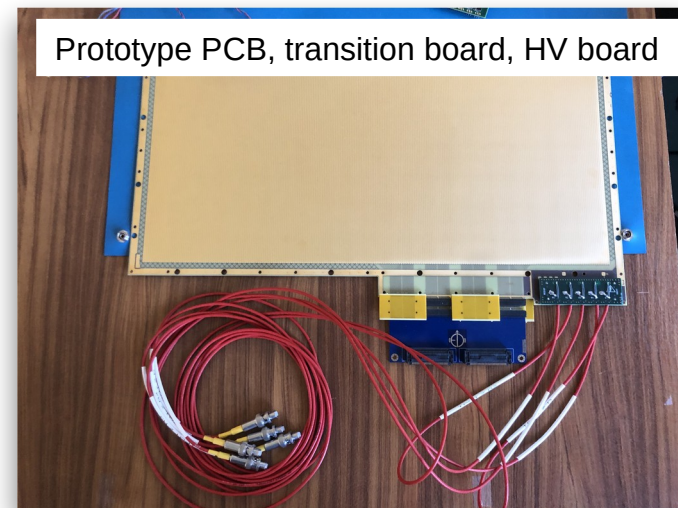
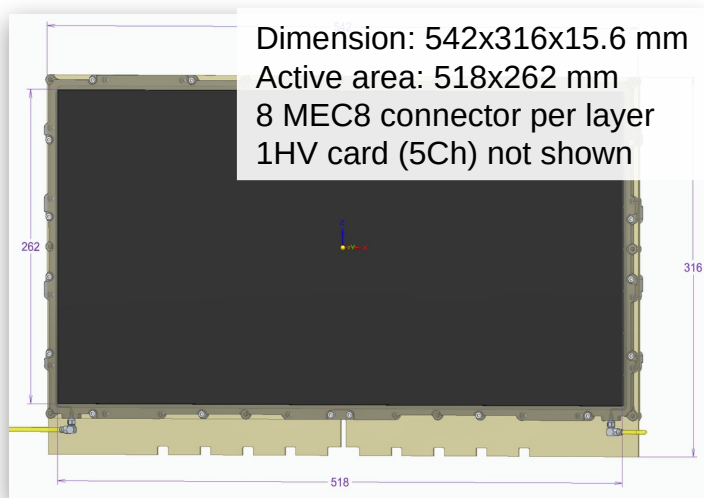

TPOT would represent a critical asset, in addition to existing solutions in sPHENIX, to calibrate the TPC:

- It allows to make the maximum use of tracks to reconstruct space charge distortions, reducing the weight on the other methods

As an illustration it allows to fully recover the Upsilon invariant mass resolution from time-averaged space charge distortions, without resorting to other methods (laser systems, digital currents)

- It provides a direct measurement of full z dependence of the distortions, critical for redundancy, cross-check of other methods, systematic assessment
- It reduces risk and speeds the deployment of precise distortion corrections, ultimately ensuring timely delivery of sPHENIX science potential

Thank you !

Backup

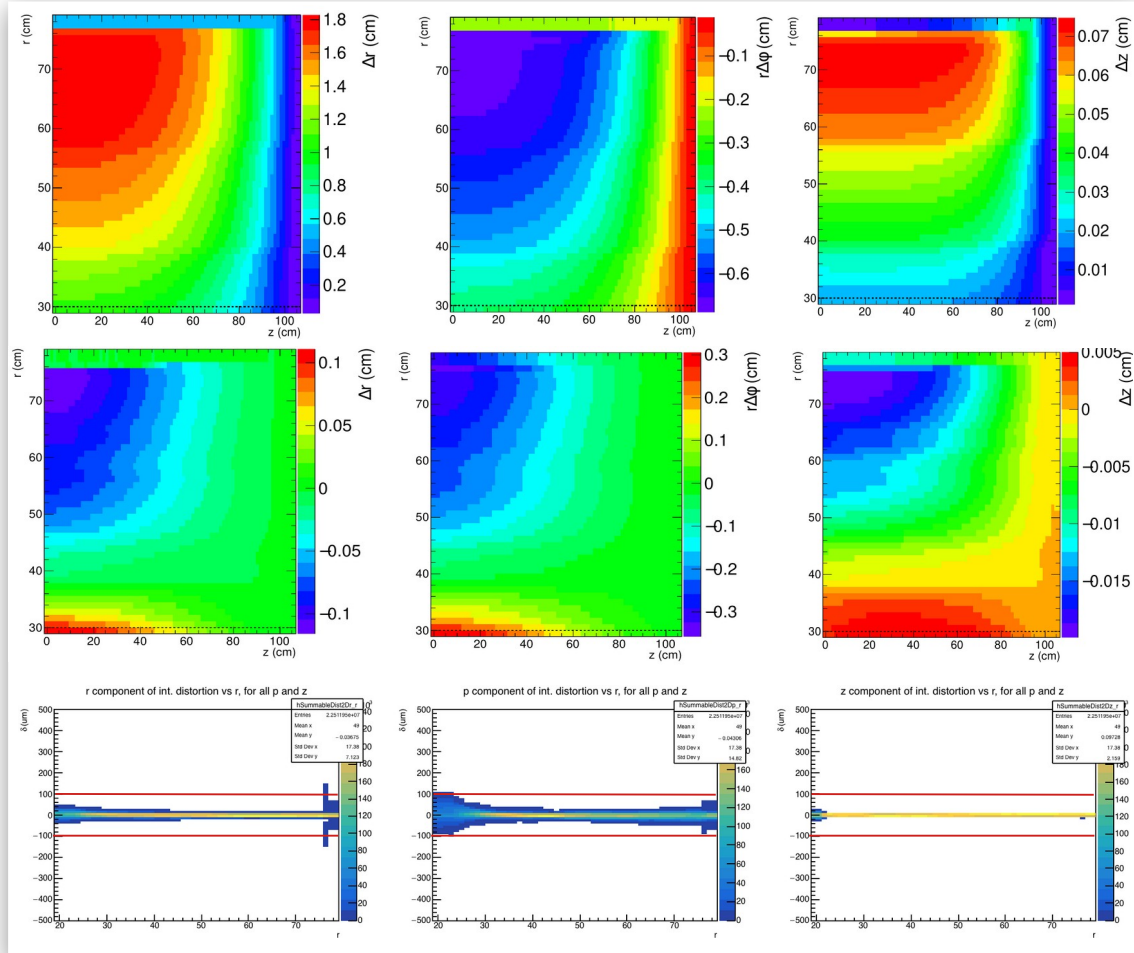

Static distortions due to E and B fields inhomogeneities and misalignment
 Are present also without beam
 Measured during commissioning
 Length scale: $O(1\text{cm})$
 Time scale: 1y data taking

Beam-induced distortions due to ions (primary \ll IBF)
 Time-average varies slowly with beam intensity/conditions
 Length scale: $O(1\text{mm})$
 Time scale: 1/2h

Event-by-event, due to particle multiplicity fluctuations
 Length scale: $< 100\mu\text{m}$
 Time scale: $O(10\text{ms})$

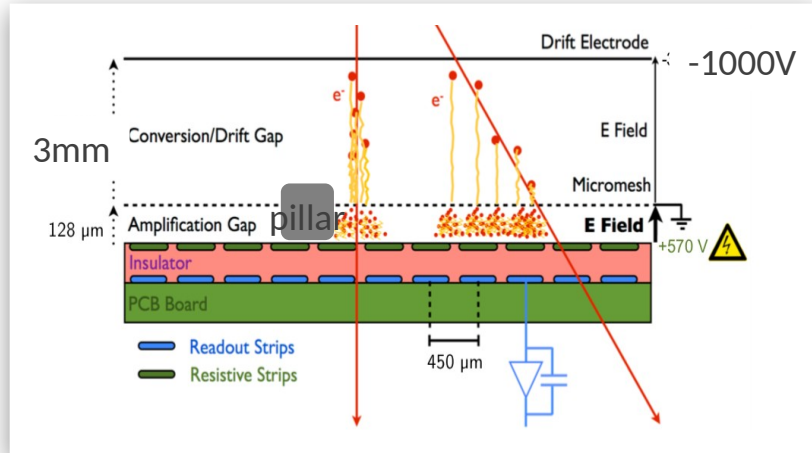

Detector technology: 1D bulk, resistive Micromegas

The resistive layer quenches discharges (sparks) by reducing amplification field when large current is induced on resistive strip

Signal induced on measurement strips via capacitive coupling

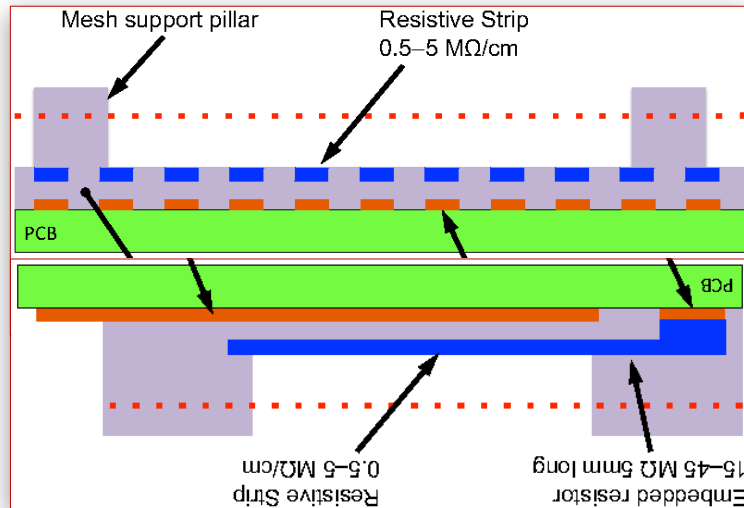

One module consists of 2x1D bulk micromegas detectors, back-to-back

Jul. 2019: First quantitative discussions with sPHENIX about an Outer Tracker detector

late 2019-early 2020: first concrete Micromegas proposal to sPHENIX Institutional Board
creation of a taskforce dedicated to optimize detector design and sPHENIX integration

Nov. 2020: writing of a preliminary “management plan” (project description, deliverable, schedule, cost breakdown)

Dec. 2020: internal review of the detector proposal with sPHENIX

Feb. 2021: setup first contract BNL-IRFU/DEDIP for building prototypes

Reconstructing distortions using tracks

- Find tracks using all detectors and large search windows
- Fit tracks using the detectors outside of the TPC
- Form residuals (cluster - track) in the TPC along Φ and z
- In each volume element (> 40000), derive distortions along Φ , r and z from $\Delta\Phi$ and Δz residuals

Remarks:

- TPC only measures Φ and z , at a given r . For δr distortions, use correlation between $\Delta\Phi$ (Δz) and track angle in the (r, Φ) (resp. (r, z)) plane
- Due to large number of volume elements, prefer analytic solution to fit, for getting distortions from residuals
- Same method applicable to line lasers, with the laser, instead of tracking to provide reference track

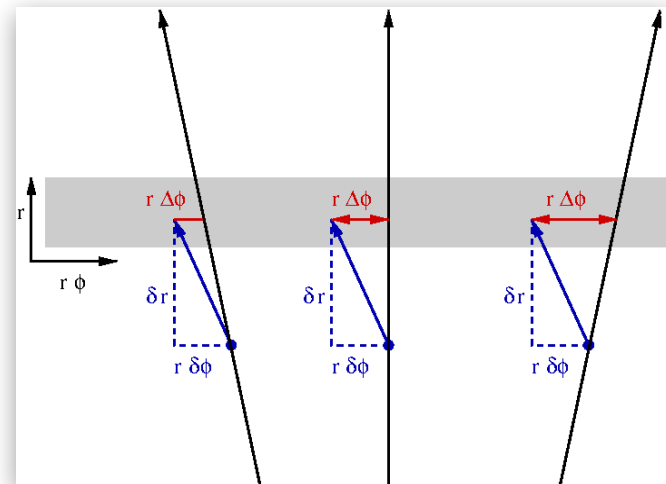
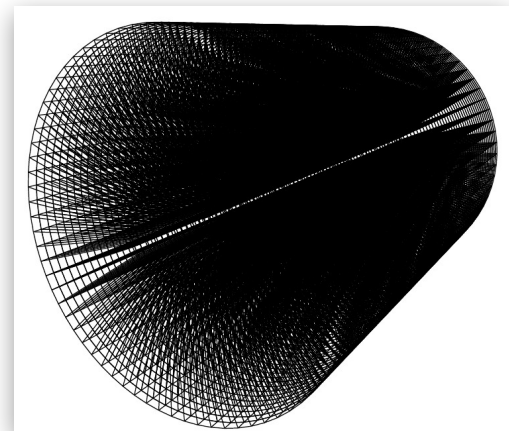

Reconstructing distortions using tracks (cont.)

For each volume element, form χ^2 from linear relation between residuals and track angles, weighted by relevant uncertainties:

$$r \Delta \phi = r \delta \phi + \delta r \cdot \tan \alpha$$

$$\Delta z = \delta z + \delta r \cdot \tan \beta$$

$$\chi^2 = \sum \frac{[r \Delta \phi - (r \delta \phi + \delta r \cdot \tan \alpha)]^2}{\sigma_{r\phi}^2} + \frac{[\Delta z - (\delta z + \delta r \cdot \tan \beta)]^2}{\sigma_z^2}$$

With:

- $\Delta \Phi$ and Δz residuals in the TPC (measured)
- α , β local track angles in (Φ, r) and (z, r) planes (measured)
- $\delta \Phi$, δr and δz the distortions (unknown)

To minimize, set the partial derivatives on the three unknown quantities $\delta \Phi$, δr and δz to zero.

Since χ^2 is quadratic in $\delta \Phi$, δr and δz , this results in three linear equations:

$$\begin{pmatrix} \sum \frac{1}{\sigma_{r\phi}^2} & 0 & \sum \frac{\tan \alpha}{\sigma_{r\phi}^2} \\ 0 & \sum \frac{1}{\sigma_z^2} & \sum \frac{\tan \beta}{\sigma_z^2} \\ \sum \frac{\tan \alpha}{\sigma_{r\phi}^2} & \sum \frac{\tan \beta}{\sigma_z^2} & \sum \frac{\tan^2 \alpha}{\sigma_{r\phi}^2} + \frac{\tan^2 \beta}{\sigma_z^2} \end{pmatrix} \cdot \begin{pmatrix} r \delta \phi \\ \delta z \\ \delta r \end{pmatrix} = \begin{pmatrix} \sum \frac{r \Delta \phi}{\sigma_{r\phi}^2} \\ \sum \frac{\Delta z}{\sigma_z^2} \\ \sum \frac{r \Delta \phi \cdot \tan \alpha}{\sigma_{r\phi}^2} + \frac{\Delta z \cdot \tan \beta}{\sigma_z^2} \end{pmatrix}$$

Minimization results in inverting a 3x3 matrix for each volume element

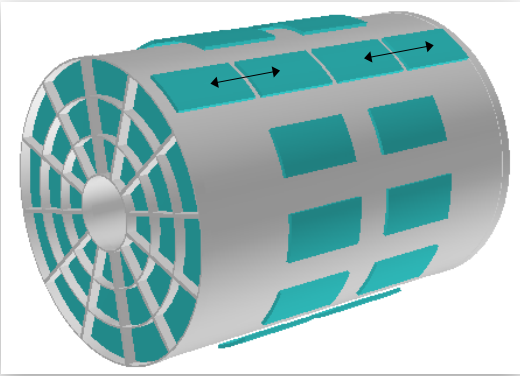

1. small z interpolation between MM modules

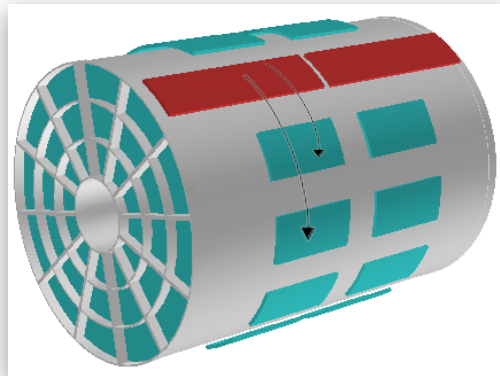

2. copy z dependence in fully equipped sector to other sectors, normalized by local measurement

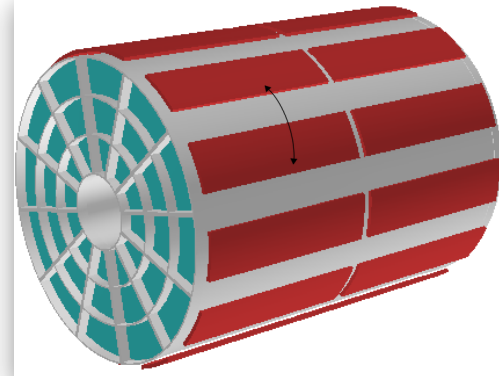

3. interpolate between sectors to cover full acceptance

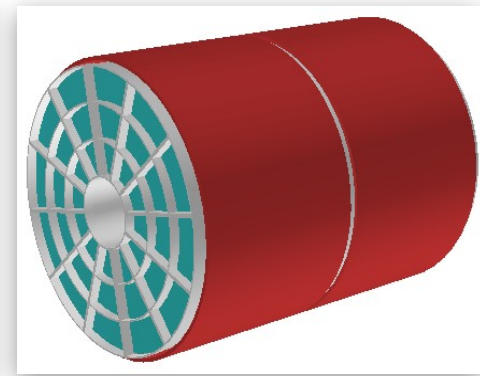

Input from diffuse laser on central membrane can also be used at steps 2 and 3 to improve normalization accuracy

Year-1 setup (2023)

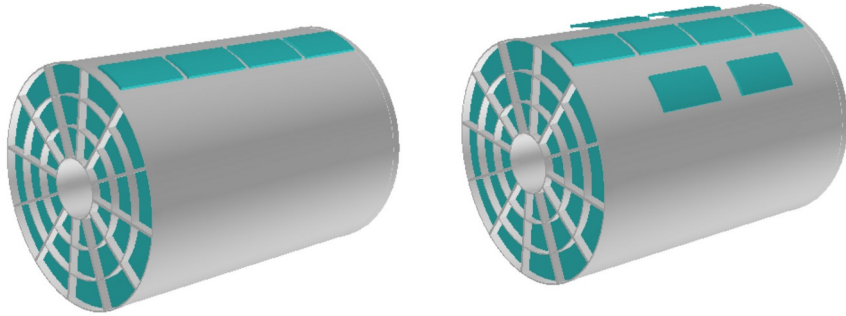

year-2 and 3 setup (2024-2025)

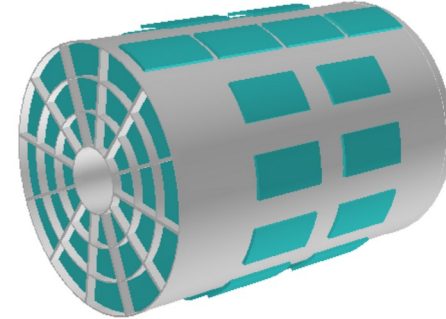

4 to 8 detectors installed depending on schedule, resources and funding profile

Extrapolation procedure to other Φ sectors will need to rely on diffuse-laser + central membrane data

No anticipated loss of momentum and inv. mass resolution but:

- no/little redundancy for checking the extrapolation procedure
- no/little redundancy for checking the z-dependent extrapolated corrections

Full setup, corresponding to performances described above

Negative impact of staged installation mitigated by the fact that Year-1 data is dedicated mostly to commissioning and low-luminosity. Year-2 (reference and CNM) and year-3 will deliver the core of sPHENIX physics.

Ability to reconstruct space charge distortions

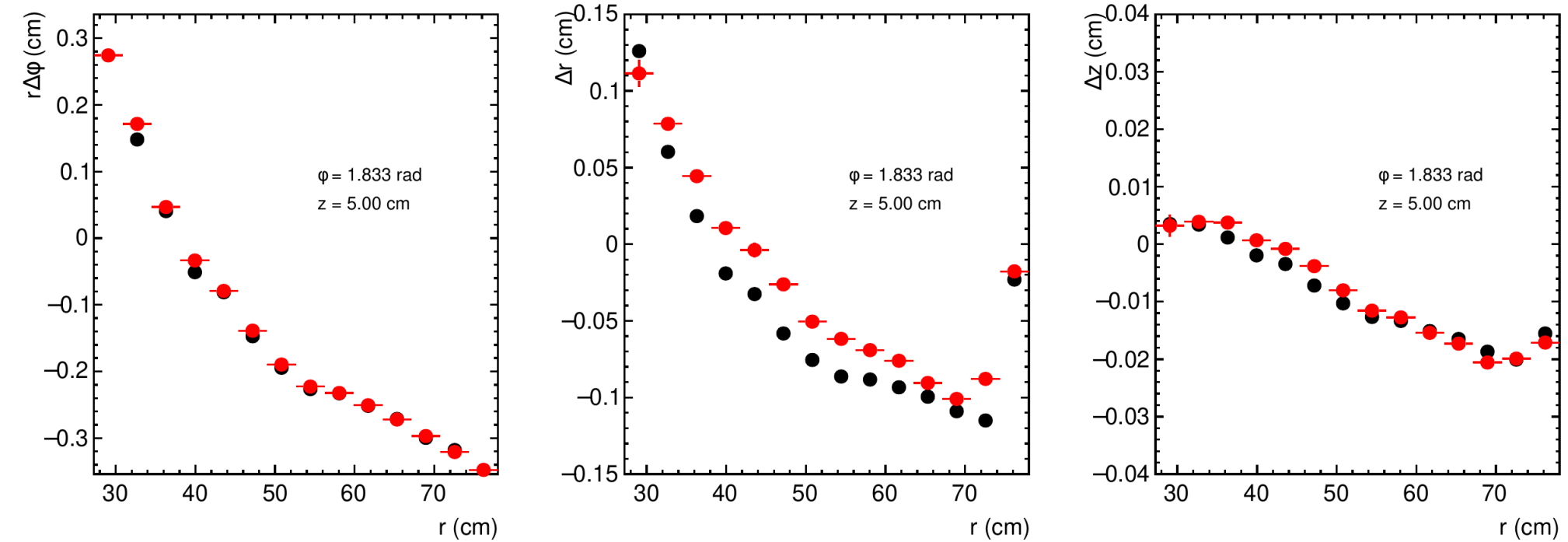

Using nominal beam-induced distortions

Black: input distortions

Red: reconstructed

Remaining difference in $|\Delta r| < 200\mu\text{m}$, being investigated (likely tracking artifacts)

Ability to reconstruct space charge distortions (cont.)

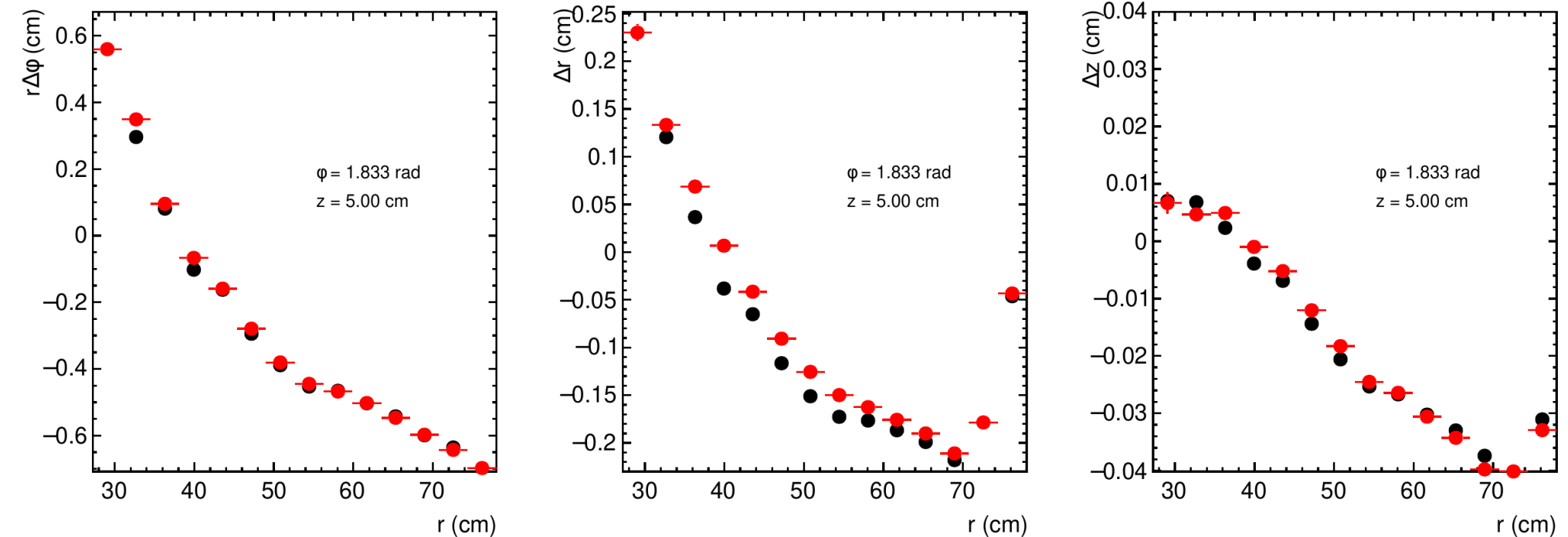

Using beam-induced distortions with x2 scale factor

Black: input distortions

Red: reconstructed

Remaining difference in $|\Delta r| < 200\mu\text{m}$, being investigated (likely tracking artifacts)